



TreGi

central heating only



Cast iron 3-pass sectional boiler with wet base furnace, complete with removable turbulators and horizontal flue passes with fins, to generate an efficient gas to water heat transfer. Available with pressure jet oil or gas (natural gas and LPG) burners achieving efficiency > 90%

Double hinged front door with ceramic insulation. Boiler lagged with fibre-glass wool.

Control panel designed to suit on-off burner complete with control and high-limit thermostats. Casing constructed from sheet steel finished in power coating . The range includes 6 boiler models with duties from 24 to 64 kW

PRODUCT ADVANTAGES

High overall seasonal efficiency with low operating costs.

Can be combined with a separate storage cylinder for domestic hot water production.

Return temperature up to 40 °C for all fuels.

INSTALLATION/MAINTENANCE ADVANTAGES

Easy to transport. Boilers come pre-assembled in a palletised wooden crate (models "TREGI 3K and 4K"), alternatively in two separate packages (one for the boiler, one for the casing).

Easy installation. Standard fittings, compact size and standard boiler plate

Easy maintenance and servicing . Front-on access to the combustion chamber; easy access to the flue gas and control panel; inspection flange and sacrificial magnesium anode.

CHARACTERISTICS			TREGi 3	TREGi 4	TREGi 5	TREGi 6	TREGi 7	TREGi 8
Input	min/max	kW	16,3/26,5	27,2/34,8	36/44,3	46,1/53,1	55/62	63/70
		Mcal/h	14,02/22,8	23,4/29,9	30,9/38,1	39,6/45,7	47,3/53,3	54,2/60,2
Output		kW	14,9/23,9	25/31,5	33/40,2	42,3/48,2	50/56,2	57,6/63,8
		Mcal/h	12,8/20,5	21,5/27,1	28,4/34,6	36,4/41,5	43/48,3	49,5/54,9
Efficiency referred min/max output		%	91,4/90,2	91,9/90,5	91,7/90,7	91,8/90,8	90,9/90,6	91,4/91,1
Efficiency referred to 30% Load		%	90,9	91,3	91,6	92	91,8	92
Exhaust losses Heat losses through flue gas burner off		%	0,1	0,1	0,1	0,1	0,1	0,1
Heat losses through flue gas burner lock-out burner on		%	7	7	7	7	7,2	7,2
Heat losses through insulation		%	2,8	2,5	2,3	2,2	2,2	1,7
Flue gas temperature Δt		°C	>140	>140	>140	>140	>140	>140
Flue gas mass flow rate		kg/s	0,01	0,013	0,017	0,02	0,024	0,027
CO2	On Natural Gas	%	9,5	9,5	9,5	9,5	9,5	9,5
CO2	On Light oil	%	12,5	12,5	12,5	12,5	12,5	12,5
Exhaust side volume Total Flue Gas Volume		dm3	22	31	39	47	55	63
Combustion chamber volume		dm3	16	22	28	34	40	46
Volumetric Thermal Load		kW/m3	1656	1582	1582	1562	1550	1522
Combustion Chamber Pressure drop		mbar	0,03/0,1	0,12/0,17	0,17/0,26	0,26/0,36	0,33/0,42	0,47/0,6
		Pa	3/10	12/17	17/26	26/36	33/42	47/60
Maximum flow temperature		°C	100	100	100	100	100	100
Minimum Return temperature		°C	40	40	40	40	40	40
Water-side pressure drop @ ΔT 10°C		mbar	4	6	10	14	20	26
		Pa	400	600	1000	1400	2000	2600
Water-side pressure drop @ ΔT 20°C		mbar	1,2	1,6	2,5	3,5	5	7
		Pa	120	160	250	350	500	700
Boiler capacity		l	13,7	17,2	20,7	24,2	27,7	31,2
		bar	4	4	4	4	4	4
Boiler maximum working pressure		kPa	400	400	400	400	400	400
Index of protection		IP	X0D (40)	X0D (40)	X0D (40)	X0D (40)	X0D (40)	X0D (40)
Boiler Weight		kg	109	135	161	187	213	239

DIMENSIONS (mm)

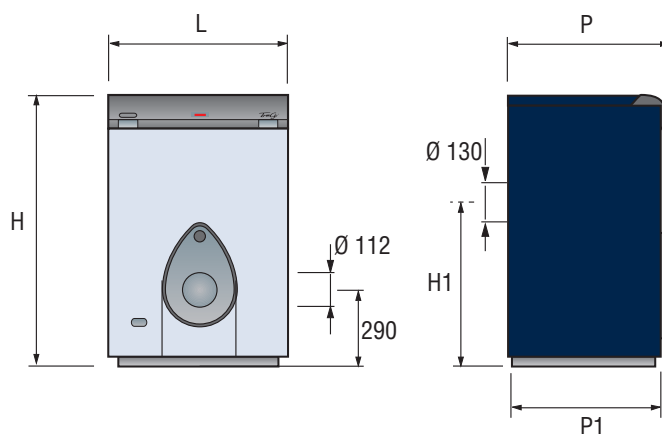

Models		TREGi 3	TREGi 4	TREGi 5	TREGi 6	TREGi 7	TREGi 8
L - Width	mm	450	450	450	450	450	450
P - Lenght	mm	490	590	690	790	890	990
P1 - Lenght	mm	460	560	660	760	860	960
H - Height	mm	850	850	850	850	850	850
H1	mm	528	528	528	528	528	528

WATER CONNECTIONS – FLUE FITTINGS

Tregi boilers are designed for central heating installations, but they can be used for combination systems if connected to hot water calorifiers. Fittings have the following specifications:

Key

MI CH Flow (Ø 1"1/4 F)
RI CH Return (Ø 1"1/4 F)

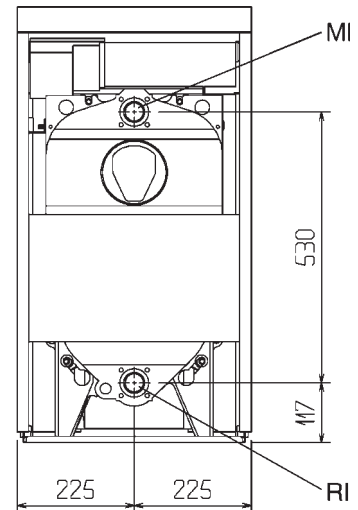

The Flues fittings and connections must be made in compliance with relevant requirement and local authority, using heat resistant, condensate resistant and stress resistant pipe-works and gaskets.

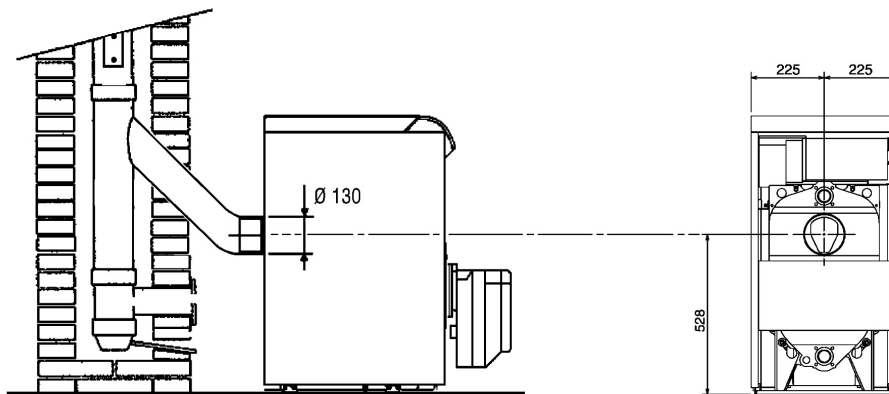

The stack must guarantee the minimum draught specified by applicable technical standards, assuming zero pressure at the flue connection. Inadequate or badly dimensioned chimneys and flues can increase combustion noise, cause condensation problems and affect combustion parameters. Exhaust pipes are potentially dangerous and can cause burns.

Flues installed without a proper insulation are potentially dangerous

Gaskets and seals must be manufactured with high temperature resistant materials (250°C e.g., filler and special silicon glues).

BURNERS MATCHING

		TREGÌ 3	TREGÌ 4	TREGÌ 5	TREGÌ 6	TREGÌ 7	TREGÌ 8
BURNERS							
GAS	GULLIVER BS 1	●	●	●			
	GULLIVER BS 2				●	●	●
LIHGT OIL	GULLIVER RG 0R	●					
	GULLIVER RG 0.3	●					
	GULLIVER RG 0.1 R	●					
	GULLIVER RG 1 NR		●	●			
	GULLIVER RG 1 RK		●	●			
	GULLIVER RG 2				●	●	
	GULLIVER RG 2 KD						●
	REG 3	●					
REG 5		●	●				

TYPICAL BOILER/CALORIFIER CONNECTION SCHEME

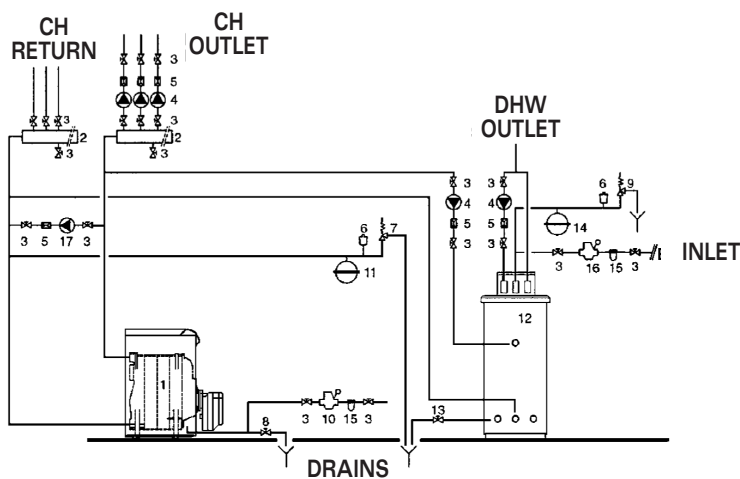

Key

- | | |
|------------------------|---------------------------------|
| 1 Boiler | 9 Storage cylinder safety valve |
| 2 CH system manifolds | 10 CH fill cock |
| 3 Isolating valves | 11 CH expansion vessel |
| 4 Pumps | 12 External storage cylinder |
| 5 Non-return valves | 13 Storage cylinder drain cock |
| 6 Automatic vent valve | 14 DHW expansion vessel |
| 7 Boiler safety valve | 15 Filter |
| 8 Boiler drain cock | 16 Pressure reducer |
| | 17 Anti-condensation pump |

WATER REFERENCE VALUES

PH	6-8
Electrical conductivity	below 200 mV/cm (25°C)
Chlorine ions	below 50 ppm
Sulphuric acid ions	below 50 ppm
Total iron	below 0.3 ppm
Alkalinity M	below 50 ppm
Total hardness	below 35° f
Sulphur ions	none
Ammonia ions	none
Silicon ions	below 30 ppm

The choice of system components and the installation are up to the installer. Installers must use their experience to guarantee a proper installation and functioning in compliance with all applicable legislation.

Circuits filled with anti-frost must be fitted with water disconnectors.

Water treatment values if required.

See the table for applicable reference values.

If needed, water supplies and recovery circuits must be conditioned by suitable treatment

SHUNT PUMP

A by pass/pump must be fitted between flow and return to avoid damage to the boiler on first ignition and on re-ignition after idle periods. This pump must guarantee a flow rate between 20% and 30% maximum flow to ensure a water return > 40 °C. Pump shutdown must also be delayed for at least 3 minutes at the beginning of extended periods of boiler shutdown. A probe well must be positioned at a distance equivalent 3 to 5 times the diameter of the water return, upstream from the water fitting, to measure the actual water return temperature and control the anti-condensation pump or the stabilisation function of temperature control systems.

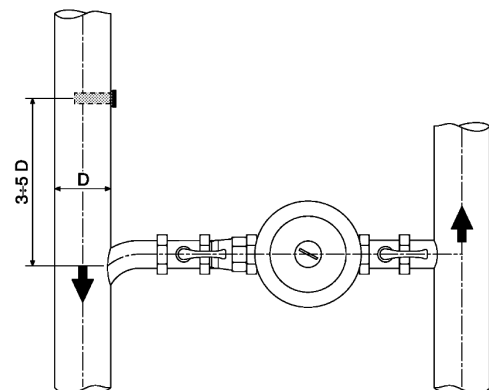

CONTROL PANEL

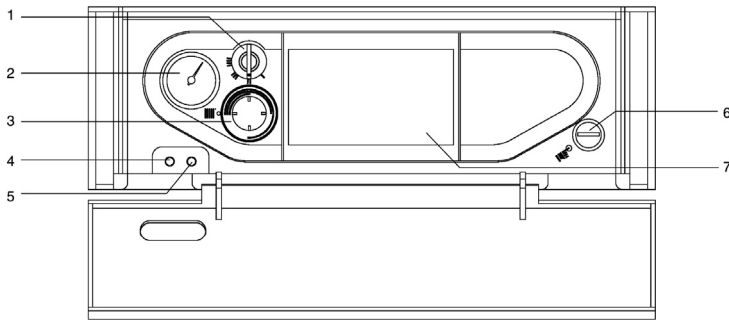

Key

- | | | | |
|---|--|---|---|
| 1 | Switch:
I Off
II On
III On
IIII On | 3 | Boiler control thermostat |
| 2 | Boiler temperature gauge | 4 | Electrical power indicator |
| | | 5 | Burner lock-out Alarm |
| | | 6 | Summer/Winter Switch
I Summer
II Winter |
| | | 7 | Calorifier temperature gauge |

TREGI

SPECIFICATIONS

3 Pass High Efficiency Cast Iron sectional floor standing boiler manufactured from element. Pressurised, triple flue pass boiler body. Boiler Maximum working pressure: 4 bar.

DESCRIPTION FOR SPECIFICATIONS

These boilers comprise:

- Casing constructed from sheet steel finished in power
- Boiler lagged with high density fibre-glass wool
- boiler body made from pre-assembled elements in MB18C cast iron
- Cast iron 3-pass sectional boiler with wet base furnace, complete with removable turbulators and horizontal flue passes with fins, to generate an efficient gas to water heat transfer and low pressure drop.
- burner mounting flange with gasket
- sensor/control probe wells
- easily accessible control panel with all necessary boiler controls, Summer/Winter switch and total high limit thermostat functions in Summer mode
- Low temperature design (minimum return temperature 35°C)
- maximum working pressure 4 bar
- compliant with 90/396/EEC directive (gas - CE marking)
- compliant with 89/336/EEC directive (electromagnetic compatibility)
- compliant with 72/23/EEC directive (low voltage)
- compliant with 92/42/EEC directive (efficiency)

ANCILLARIES MATERIALS

- burner electrical connections
- installation, operation and maintenance manual
- Hydraulic test certificate
- product identification plate
- spare parts catalogue

